

# DUR-A-LIFT®

## DPM 52

### Reaching New Heights

DPM model offers options for double person baskets in our DU and DP series.



Conveniently positioned controls will allow the operator to be more effective when maneuvering their materials.



-35° Boom angle gives the operator the flexibility of ground level basket access for overall ease of use.



### UP TO 57' WORKING HEIGHT



[sales@dur-a-lift.com](mailto:sales@dur-a-lift.com)  
[www.dur-a-lift.com](http://www.dur-a-lift.com)

Dur-A-Lift Inc, P.O. Box 31, George, Iowa 51237  
(877) 4-DURALIFT (877) 438-7254 | Fax: (712) 475-2809

## SPECIFICATIONS

### DPM 52

Height to Bottom of Platform	52'
Working Height	57'
Side Reach (MH, DU, AND DP Models)	31'6"
Approximate Stowed Travel Height	11'8"
Platform Capacity (MH Models)	400#
Platform Capacity Using Jib (DU Model)	400#
Platform Capacity not Using Jib (DU Model)	550#
Platform Capacity (DP Model)	600#
Approximate Weight	4500#
Articulating Arm Travel (MH, DU, and DP)	0 to 80
Main Boom Travel	-35 to 80
Extension Travel	120"

Minimum GVWR will change significantly depending on make of chassis and stabilizer option. Dur-A-Lift Inc. reserves the right to improve models and change specifications without notice or obligation. Dur-A-Lift equipment meets or exceeds all applicable ANSI Standards as of the date of manufacture.

## STANDARD FEATURES

- Proportional Controls
- Lower Override Controls
- Engine Start/Stop from Basket
- Basket Access from Ground
- Compensated Upper Boom
- Insulated Cat "C" Extension Boom
- Hydraulic Basket Leveling
- Continuous Rotation

## DPM-52 MH FEATURES

- Up to 1000# Jib and Winch
- Upper and Lower Winch Control
- 400# Basket Capacity
- 24" X 30" Fiberglass Basket
- 180° Basket Rotator

## DPM-52 DP FEATURES

- 600# Basket Capacity
- 24" X 48" Fiberglass
- 180° Basket Rotator

## DPM-52 DU FEATURES

- Up to 1000# Jib and Winch
- 550# Basket Capacity When Not Using Winch
- 400# Basket Capacity When Using Winch
- 24" X 42" Fiberglass Basket
- 24" X 42" Aluminum Basket
- 100° Basket Rotator

## Options

- Joystick and Lockout Controls
- High Electrical Resistant Controls
- Outriggers
- Basket Liner for Fiberglass Baskets
- Fiberglass Main and Articulating Booms
- Tool Circuits
- D.C. Backup System
- 180° Basket Rotator (DU)
- Aluminum Basket

DPM 52 Reach Diagram

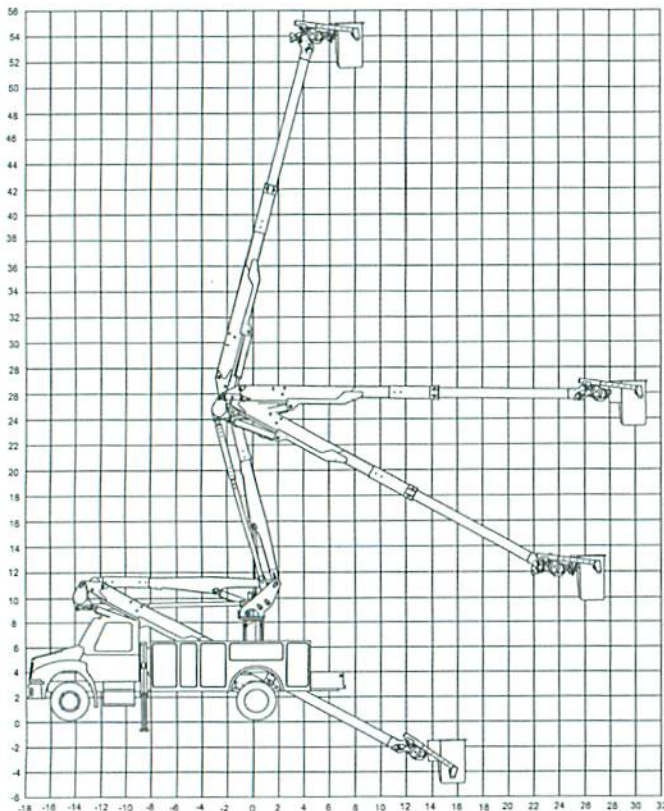

Basket shown in end hung position

This aerial lift is sold and serviced by: