

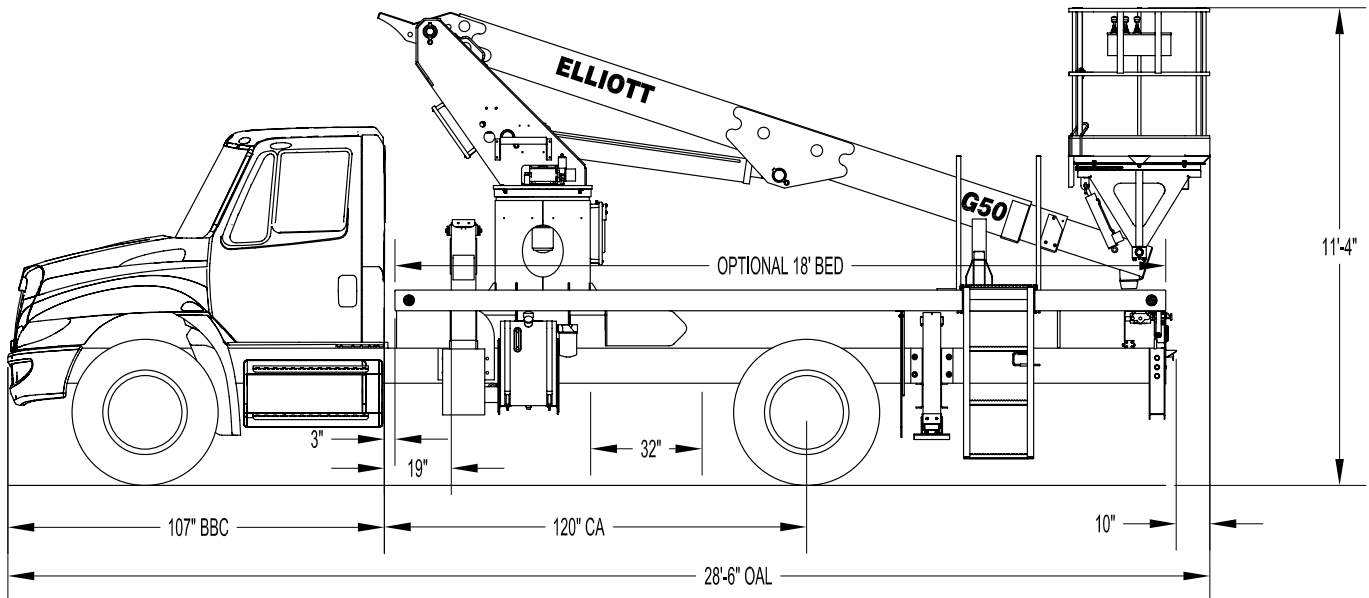

G50F SIDE VIEW DIAGRAM



- | | | | |
|--|---------------------|---|---------------------|
| • Working Height | 55'/16.7 m | • Powered Boom Sections | 3 |
| • Working Side Reach | 37'/11.3 m | • Overall Height | 11'4"/3.4 m |
| • Platform Capacity | 600 lbs/272 kg | • Unit Weight (Bare) | 11,000 lbs/4,989 kg |
| • Platform Size | 40x60 in/102x152 cm | • Outrigger Spread Main | 12'6"/3.8 m |
| • Platform Type | Top-Mount | • Outrigger Spread Auxiliary | 8'/2.4 m |
| • Lifting Capacity (Main Winch) | 5,900 lbs/2,676 kg | • Front Gross Axle Weight Rating | 10,000 lbs/4,536 kg |
| • Jib Winch | 1,000 lbs/454 kg | • Rear Gross Axle Weight Rating | 19,000 lbs/8,618 kg |

TECHNICAL SPECIFICATIONS

Maximum Platform Height: 50' ground to platform floor.

Working Range: 55' max. height and 37' max. side reach.

Work Platform: 40x60" Top-Mount work platform with 40" high rails. Equipped with two safety lanyard attachment loops and two safety harnesses and 72" lanyards. Platform capacity 600 lbs.

Platform Leveling System: Hydraulic "closed" system consisting of twin platform cylinders interacting with a boom-actuated master cylinder mounted in boom support turret. System provided with factory-set relief valves to compensate for oil expansion or overload during platform leveling operation. Remote releveling controls provided in platform and at ground controls to give precise releveling capability.

Platform Controls: Three individual proportional electronic controllers meter pilot-operated, pressure-compensated modulating valves. Boom ground controls are mounted on curbside of turret. Remote controls for boom operations from platform operate from a removable remote control box. Hi/Lo range, start/stop and engine speed toggle controls are also located at platform. Electric remote control cable extends through the electrical slip ring to cable carrier on side of boom to extending boom sections.

Lower Controls: Mounted on curbside of turret.

Outrigger Controls: Parallel open-center stack valve for lever-operated control of right and left outriggers. The outrigger valves are mounted at the rear, under each corner of the bed with roadside valve controlling roadside outriggers and curbside valve controlling curbside outriggers.

Outriggers: "A" type main outriggers

with 12'6" spread. "A" type underslung secondary outriggers with 8' spread.

Frame: One piece, all welded, box-type fabrication with integral outrigger mounts.

Turret: Reverse offset turret is one-piece weldment mounted on turret box. Turret rotates on large diameter ball bearing.

Rotation: Continuous turret rotation with no stops. Hydraulic motor drives turret through self-locking gear box.

Boom: Steel rectangular tube sections. Assembly includes heavy-duty cylinder fittings, pivot pins, and replaceable wear pads.

Boom Extension: Two opposing "piggyback" extension cylinders extend the boom sections.

Lift: One single-acting full displacement, long stroke cylinder, provides smooth and stable boom elevation. Holding valve prevent boom from falling in event of hose failure.

Cylinders: All cylinders use microhoned cylinder tubing, chrome shafts, top grade packing and protective rod wipers. Cylinder-mounted holding valves provided on all load-holding cylinders.

Hoses: All high pressure hoses are wire braid reinforced with a minimum safety factor of 4 to 1.

Oil Tank Capacity: 35 gallon mounted to truck frame on roadside.

Hydraulic System: Operating pressure approximately 2,500 PSI. System is parallel open center type and is equipped with liquid-filled pressure gauge. Oil is supplied to upper cylinders through hydraulic union in center of turret to cable carrier along side of the boom.

Pump: Gear type, direct mount to truck PTO.

PTO: Heavy-duty, high-speed. Cable engaged from cab.

Cab Equipment: PTO cable with indicator lights installed in truck cab. Engine speed control and start/stop installed with control switches in platform remote control box and also located at lower controls. U/L approved 5:BC dry chemical fire extinguisher installed in truck cab.

Operators Manual & Video: Two CDs and one printed copy of operation, maintenance, safety and parts manual provided with each unit. Operational and safety video provided at delivery.

Installation: Unit installed on truck, painted, system and tank filled with oil, tested, inspected, and ready to operate.

Standard Paint: Paint boom and turret red, outriggers red, and bed and boxes black. Top of bed painted with black nonskid surface.

Bumper: Bureau of Motor Carrier Safety rear bumper.

Weight: Approximately 11,000 lbs. with 18' steel-floor bed less truck.

Truck Chassis Required: Approx. 120" C.A. RBM 900,000 in.-lb. per rail, 10,000 lb. front axle and 25,999 lb. GVWR required. Trucks must have increased cooling, heavy-duty front and rear springs, 12V electrical system with high capacity alternator, cab clearance stop/tail/backup lights, and I.D. lamps. Recommended GVWR is minimum for HIREACH with flatbed only. Contact factory when additional equipment is to be added.

Options:

5,900 lb Capacity Boom Winch

1,000 lb Capacity Platform Jib Winch

Welder, Air, 110V Lines and More to Platform.

Custom Toolboxes

Much more....

Elliott Equipment Company reserves the right to change the specification of any unit at any time without prior notice. This brochure is only a statement of general specifications on the date of this publication. For more detailed info on specific Elliott trucks go to www.elliottequip.com

MAXIMUM WORKING LOADS

**MAXIMUM WORKING LOADS
CRANE OPERATION
MODEL G50**

WINCH LINE LOAD (POUNDS) WITH BUCKETS OR PLATFORM REMOVED

USE OUTRIGGERS AT ALL TIMES • AVOID JERKING LOAD

360° RADIUS • DEDUCT FOR DOWNHAUL WEIGHT • USE 2 PART LINE FOR LOADS OVER 2700 LBS

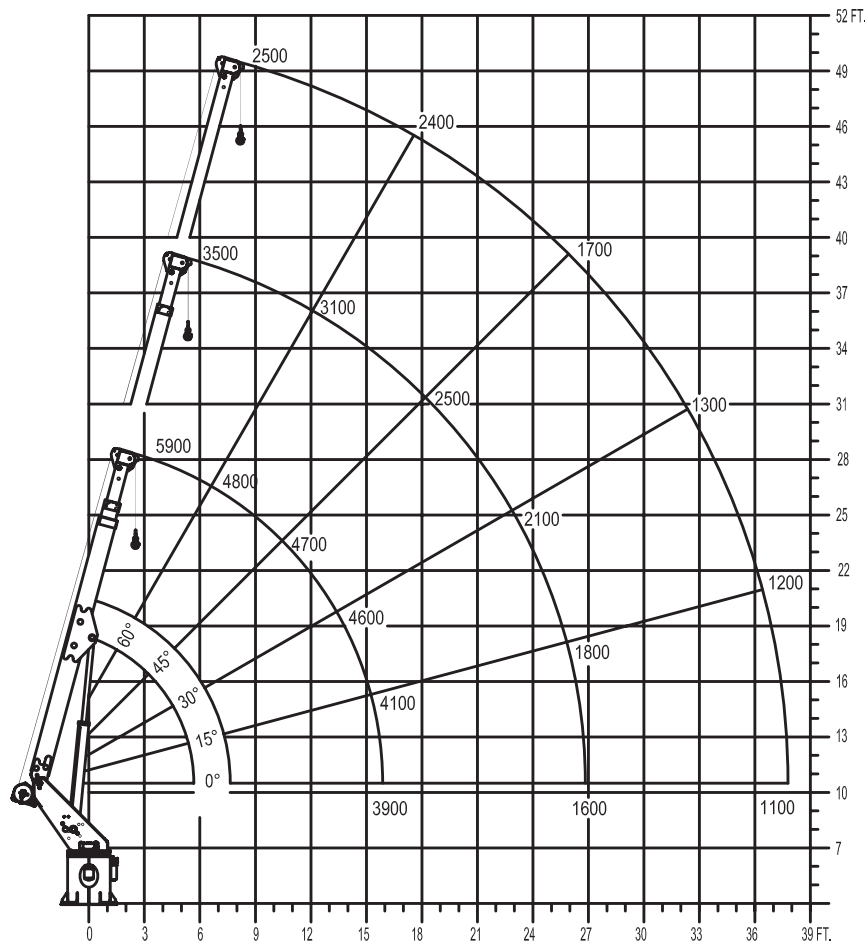

DEDUCT 400 LBS. WITH BUCKETS OR PLATFORM ATTACHED

ELLIOTT

EQUIPMENT COMPANY

DO NOT PAINT OVER ANY LABELS

1068140 040203

CHASSIS DATA

	G50F
Wheelbase (WB)	187" / 475 cm
Cab to Axle (CA)	120" / 305 cm
Cab to End of Frame (EOF)	220" / 559 cm
Frame Section Modulus	7.5 in3 / 120,000 psi / 827,371 kPa
Front Axle Gross Weight Rating	10,000 lb / 4,536 kg
Rear Axle Gross Weight Rating	19,000 lb / 8,618 kg
Extended Front Frame	N/A

Chassis data is minimum general requirements-not for engineering.
Actual dimensions and truck data will depend on truck selection and axle configuration.

OPTIONS



Radio Remote Control

Interference protected radio remotes let you get closer to your work and have full control over your machine.



Material Handling Jib

Equip your HiReach platform with a material handling jib crane to handle up to 1,000 pounds.



Boom-Mounted Winch

Take advantage of the 5,900 lb capacity 2 speed hydraulic winch with 1/2" cable.



Outrigger Pad Holders

Outrigger pad holders safely store your pads for travel and leave plenty of room for tool boxes.



Bed Accessories

Mount a wide variety of tool accessories including welders, power washers, and generators on the bed with lines to the platform.



Platform Accessories

Choose from a list of platform accessories including 110V outlets, welding leads, hydraulic tools, and much more.



Custom Design Engineering

Customize your HiReach by adding lights, tools, special paint, and much more. Let Elliott's engineering team design the right configuration for your business.



Line Body

Let us work with you to customize a line body to secure your tools and supplies the the best way for your application.